

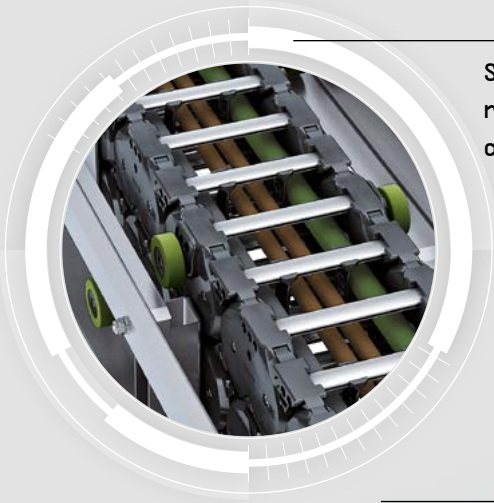

# CABLE CARRIER SYSTEMS FOR PORT CRANES

# KABELSCHLEPP

TSUBAKI KABELSCHLEPP



Suitable also for  
roller-mounted  
applications (RSC)



Floating  
moving  
device



Replaceable  
glide shoes

Cable carrier with  
integrated roller



Condition  
monitoring

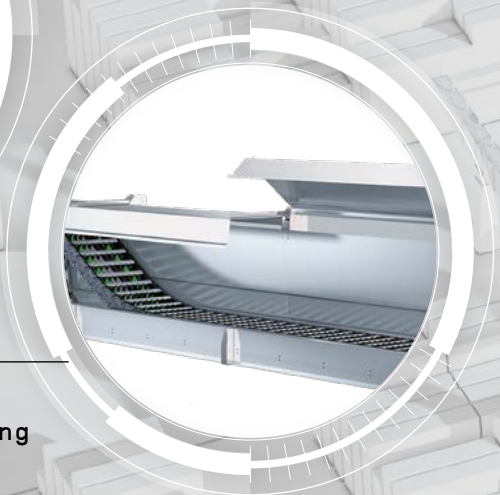

System channel and  
maintenance-friendly housing  
in galvanized or stainless  
steel

COSTS DOWN – SERVICE LIFE UP

# CABLE CARRIER SYSTEMS FOR PORT CRANES

TSUBAKI KABELSCHLEPP develops customized solutions for cable carrier systems in cranes. Our decades of experience from hundreds of realized projects in various industries with diverse demands on our cable carrier systems, lead to new custom and application-specific solutions for our customers. Our specialists will support you from the planning and design stage through to the onsite installation and start-up of the tested complete system.



Lift-stop device  
and fasteners  
to attach pipes  
and hoses to the  
outside of the  
channel

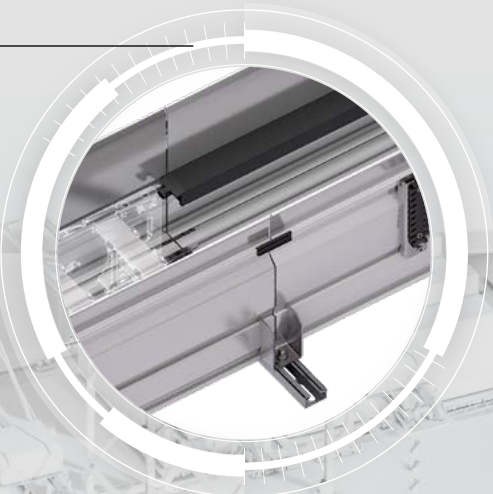

Mounting kits external  
and internal

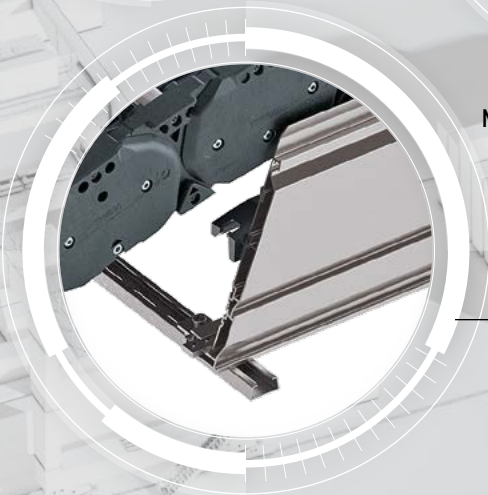

Aluminum guide channel  
with gliding support

# YOUR PARTNER FOR PROJECTS

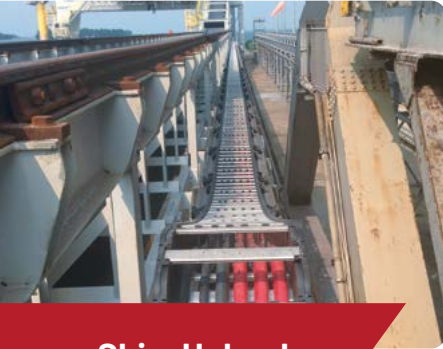

**Ship-Unloader**

Location: Indonesia  
Travel length: 300 m  
Speed: 1.5 m/s  
Acceleration:  $0.5 \text{ m/s}^2$   
Additional load: 15 kg/m  
Cable carrier: MC1300



**Mobile onshore power supply**

Location: Nottingham, England  
Travel length: 215 m  
Speed: 0.4 m/s  
Acceleration:  $0.08 \text{ m/s}^2$   
Additional load: 5 kg/m  
Cable carrier: 2 x 5 band MC1250



**Ship to shore crane  
with roller supported chain system**

Travel length: 115 m  
Speed: 4.0 m/s  
Acceleration:  $0.5 \text{ m/s}^2$   
Additional load: 7 kg/m  
Cable carrier: RSC TKHD90



**Ship to shore crane  
with roller supported chain system**

Travel length: 100 m  
Speed: 4.0 m/s  
Acceleration:  $0.5 \text{ m/s}^2$   
Additional load: 5 kg/m  
Cable carrier: RSC MC0950

# TOTALTRAX® COMPLETE SYSTEMS FROM PLANNING TO THE FINAL COMPLETE SYSTEM

Use our know-how. Working jointly with you, our experienced specialists can provide pre-sale support, including planning and design services through after sales service and support.

One order, one contact person, components optimally matched to each other, including the cable and hose carrier, the electrical cables, the hydraulic and pneumatic hoses and the connectors.

You receive the complete system in one delivery along with a guarantee certificate, if desired – in short: TOTALTRAX®. Reduce your storage costs for cable and hose carriers, cables and connectors with TOTALTRAX®. We supply all components Just-In-Time to your production facility or directly to the installation site.



## EXPERT INSTALLATION BY OUR SERVICE TEAM

Let our service team handle the planning and execution of the installation of cable and hose carrier systems. We provide the support you need:

- » complete assembly including the guide channel and the substructure
- » uncoiling and assembling cable and hose carrier systems for long travel applications
- » installation in harsh conditions at great height
- » commissioning and acceptance



## YOUR EXPERT



### PASCAL BERG

Industry Manager Cranes and Long Travel  
Business Unit Cable Carrier Systems

+49 2762 4003-198

pascal.berg@kabelschlepp.de

kabelschlepp.de

## CONTACT

### TSUBAKI KABELSCHLEPP GmbH

Daimlerstraße 2  
D-57482 Wenden-Gerlingen

Fon: +49 2762 4003-0

Fax: +49 2762 4003-220

E-mail: [info@kabelschlepp.de](mailto:info@kabelschlepp.de)  
[tsubaki-kabelschlepp.com](http://tsubaki-kabelschlepp.com)



### Your contact:

Brands for TSUBAKI KABELSCHLEPP GmbH are protected as national or international trademarks in the following countries:  
[tsubaki-kabelschlepp.com/trademarks](http://tsubaki-kabelschlepp.com/trademarks)



The complete product range at  
[tsubaki-kabelschlepp.com](http://tsubaki-kabelschlepp.com)